



# STANDARD

**ANSI/ASHRAE Standard 62.1-2016**

(Supersedes ANSI/ASHRAE Standard 62.1-2013)

Includes ANSI/ASHRAE addenda listed in Appendix K

# Ventilation for Acceptable Indoor Air Quality

See Appendix K for approval dates by the ASHRAE Standards Committee, the ASHRAE Board of Directors, and the American National Standards Institute.

This Standard is under continuous maintenance by a Standing Standard Project Committee (SSPC) for which the Standards Committee has established a documented program for regular publication of addenda or revisions, including procedures for timely, documented, consensus action on requests for change to any part of the Standard. The change submittal form, instructions, and deadlines may be obtained in electronic form from the ASHRAE website ([www.ashrae.org](http://www.ashrae.org)) or in paper form from the Senior Manager of Standards. The latest edition of an ASHRAE Standard may be purchased from the ASHRAE website ([www.ashrae.org](http://www.ashrae.org)) or from ASHRAE Customer Service, 1791 Tullie Circle, NE, Atlanta, GA 30329-2305. E-mail: [orders@ashrae.org](mailto:orders@ashrae.org). Fax: 678-539-2129. Telephone: 404-636-8400 (worldwide), or toll free 1-800-527-4723 (for orders in US and Canada). For reprint permission, go to [www.ashrae.org/permissions](http://www.ashrae.org/permissions).

© 2016 ASHRAE

ISSN 1041-2336



**ASHRAE Standing Standard Project Committee 62.1**  
**Cognizant TC: 4.3, Ventilation Requirements and Infiltration**  
**SPLS Liaison 2011–2013: Steven J. Emmerich**  
**SPLS Liaison 2013–2016: John F. Dunlap**  
**ASHRAE Staff Liaison: Mark Weber**

Hoy R. Bohanon, Jr., *Chair* (2015–2016)  
*Co-Vice Chair* (2014–2015)  
Roger L. Hedrick, *Chair* (2013–2015)  
Hamid Habibi, *Vice-Chair* (2015–2016)  
Wayne R. Thomann, *Co-Vice Chair* (2013–2015)  
Hugo O. Aguilar  
Gary L. Berlin  
Gregory Brunner  
Mark P. Buttner  
Gustavo G. Chaves  
Eric Chen  
James K. Chisholm  
Waller S. Clements  
Leonard A. Damiano  
Abdel K. Darwich  
Helen D. Davis  
Paul L. Doppel  
Francis J. Fisher, Jr.

Kevin B. Gallen  
Gregg Gress  
Brian J. Hafendorfer  
Donald C. Herrmann  
Nathan L. Ho  
Tianzhen Hong  
Elliott Horner  
Gregg Gress  
Eli P. Howard, III  
Bashar Madani  
John K. McFarland  
Molly E. McGuire  
Stephany I. Mason  
Wayne E. Morris  
Adam S. Muliawan  
Kashif Nawaz  
John Nelson, Jr.

Jianlei Niu  
Jonathan W. W. Olsen  
Laura G. Petrillo-Groh  
Lisa J. Rogers  
Duane P. Rothstein  
Chandra Sekhar  
Charles J. Seyffer  
Harris M. Sheinman  
Jeffrey K. Smith  
Kirk J. Stache  
Dennis A. Stanke  
W. Brad M. Stanley  
Erica Stewart  
Pawel Wargocki  
Josiah Wiley  
Scott D. Williams  
Marwa Zaatari

---

**ASHRAE STANDARDS COMMITTEE 2015–2016**

Douglass T. Reindl, *Chair*  
Rita M. Harrold, *Vice-Chair*  
James D. Aswegan  
Niels Bidstrup  
Donald M. Brundage  
John A. Clark  
Waller S. Clements  
John F. Dunlap  
James W. Earley, Jr.  
Keith I. Emerson

Steven J. Emmerich  
Julie M. Ferguson  
Walter T. Grondzik  
Roger L. Hedrick  
Srinivas Katipamula  
Rick A. Larson  
Lawrence C. Markel  
Arsen K. Melikov  
Mark P. Modera  
Cyrus H. Nasser

Heather L. Platt  
David Robin  
Peter Simmonds  
Dennis A. Stanke  
Wayne H. Stoppelmoor, Jr.  
Jack H. Zarour  
Julia A. Keen, *BOD ExO*  
James K. Vallort, *CO*

Stephanie C. Reiniche, *Senior Manager of Standards*

---

**SPECIAL NOTE**

This American National Standard (ANS) is a national voluntary consensus Standard developed under the auspices of ASHRAE. *Consensus* is defined by the American National Standards Institute (ANSI), of which ASHRAE is a member and which has approved this Standard as an ANS, as “substantial agreement reached by directly and materially affected interest categories. This signifies the concurrence of more than a simple majority, but not necessarily unanimity. Consensus requires that all views and objections be considered, and that an effort be made toward their resolution.” Compliance with this Standard is voluntary until and unless a legal jurisdiction makes compliance mandatory through legislation.

ASHRAE obtains consensus through participation of its national and international members, associated societies, and public review.

ASHRAE Standards are prepared by a Project Committee appointed specifically for the purpose of writing the Standard. The Project Committee Chair and Vice-Chair must be members of ASHRAE; while other committee members may or may not be ASHRAE members, all must be technically qualified in the subject area of the Standard. Every effort is made to balance the concerned interests on all Project Committees.

The Senior Manager of Standards of ASHRAE should be contacted for

- a. interpretation of the contents of this Standard,
- b. participation in the next review of the Standard,
- c. offering constructive criticism for improving the Standard, or
- d. permission to reprint portions of the Standard.

**DISCLAIMER**

ASHRAE uses its best efforts to promulgate Standards and Guidelines for the benefit of the public in light of available information and accepted industry practices. However, ASHRAE does not guarantee, certify, or assure the safety or performance of any products, components, or systems tested, installed, or operated in accordance with ASHRAE’s Standards or Guidelines or that any tests conducted under its Standards or Guidelines will be nonhazardous or free from risk.

**ASHRAE INDUSTRIAL ADVERTISING POLICY ON STANDARDS**

ASHRAE Standards and Guidelines are established to assist industry and the public by offering a uniform method of testing for rating purposes, by suggesting safe practices in designing and installing equipment, by providing proper definitions of this equipment, and by providing other information that may serve to guide the industry. The creation of ASHRAE Standards and Guidelines is determined by the need for them, and conformance to them is completely voluntary.

In referring to this Standard or Guideline and in marking of equipment and in advertising, no claim shall be made, either stated or implied, that the product has been approved by ASHRAE.

**CONTENTS**  
**ANSI/ASHRAE Standard 62.1-2016,**  
**Ventilation for Acceptable Indoor Air Quality**

<b>SECTION</b>	<b>PAGE</b>
Foreword .....	2
1 Purpose .....	2
2 Scope .....	3
3 Definitions .....	3
4 Outdoor Air Quality .....	5
5 Systems and Equipment .....	5
6 Procedures .....	11
7 Construction and System Start-Up .....	19
8 Operations and Maintenance .....	21
9 References .....	21
Normative Appendix A: Multiple-Zone Systems .....	24
Normative Appendix B: Separation of Exhaust Outlets and Outdoor Air Intakes .....	27
Informative Appendix C: Summary of Selected Air Quality Guidelines .....	29
Informative Appendix D: Rationale for Minimum Physiological Requirements for Respiration Air Based on CO <sub>2</sub> Concentration .....	40
Informative Appendix E: Acceptable Mass Balance Equations for Use with the IAQ Procedure .....	42
Informative Appendix F: Information on Selected National Standards and Guidelines for PM <sub>10</sub> , PM <sub>2.5</sub> , and Ozone .....	44
Informative Appendix G: Application and Compliance .....	45
Informative Appendix H: Documentation .....	47
Informative Appendix I: National Ambient Air Quality Standards (NAAQS) .....	50
Informative Appendix J: Informative References .....	51
Informative Appendix K: Addenda Description Information .....	52

**NOTE**

**Approved addenda, errata, or interpretations for this standard can be downloaded free of charge from the ASHRAE website at [www.ashrae.org/technology](http://www.ashrae.org/technology).**

**© 2016 ASHRAE**

1791 Tullie Circle NE · Atlanta, GA 30329 · [www.ashrae.org](http://www.ashrae.org) · All rights reserved.

ASHRAE is a registered trademark of the American Society of Heating, Refrigerating and Air-Conditioning Engineers, Inc.  
ANSI is a registered trademark of the American National Standards Institute.

**(This foreword is not part of this standard. It is merely informative and does not contain requirements necessary for conformance to the standard. It has not been processed according to the ANSI requirements for a standard and may contain material that has not been subject to public review or a consensus process. Unresolved objections on informative material are not offered the right to appeal at ASHRAE or ANSI.)**

## FOREWORD

The 2016 edition of ANSI/ASHRAE Standard 62.1-2016 combines Standard 62.1-2013 and the fourteen approved and published addenda to the 2013 edition. Specific information on the contents of each addendum and approval dates for addenda are included in Informative Appendix K.

First published in 1973 as Standard 62, Standard 62.1 is updated on a regular basis using ASHRAE's continuous maintenance procedures. Addenda are publicly reviewed, approved by ASHRAE and ANSI, and published as a supplement at approximately 18 months. The complete collection of addenda to the standard are incorporated into the current edition and published as a new edition every three years.

Standard 62.1 has undergone key changes over the years, reflecting the ever-expanding body of knowledge, experience, and research related to ventilation and air quality. While the purpose of the standard remains unchanged—to specify minimum ventilation rates and other measures intended to provide indoor air quality (IAQ) that is acceptable to human occupants and that minimizes adverse health effects—the means of achieving this goal have evolved. In its first edition, the standard adopted a prescriptive approach to ventilation by specifying both minimum and recommended outdoor airflow rates to obtain acceptable indoor air quality for a variety of indoor spaces. In its 1981 edition, the standard reduced minimum outdoor airflow rates and introduced an alternative performance-based approach, the Indoor Air Quality Procedure, which allowed for the calculation of the amount of outdoor air necessary to maintain the levels of indoor air contaminants below recommended limits. Today, the standard includes three procedures for ventilation design, the IAQ Procedure, the Ventilation Rate Procedure, and the Natural Ventilation Procedure.

In its 1989 edition, in response to a growing number of buildings with apparent indoor air quality problems, the standard increased minimum outdoor airflow rates significantly and introduced a requirement for finding outdoor air intake flow requirements for multiple-zone recirculating systems.

The 1999 and 2001 editions made several minor changes and clarifications that did not impact the minimum required outdoor airflow rates. The 2004 edition—the last time the standard was revised in its entirety—modified the IAQ Procedure to improve enforceability, but more significantly it modified the Ventilation Rate Procedure, changing both the minimum outdoor airflow rates and the procedures for calculating both zone-level and system-level outdoor airflow rates. The 2007, 2010, and 2013 editions of the standard provided

some significant updates, but the changes primarily focused on usability and clarity.

The 2016 edition revises and improves the standard in several ways. Scope was changed to remove residential occupancies from 62.1 with a concurrent change in 62.2 to add all residential spaces. Significant changes include the following:

- Previously, Standard 62.1 had responsibility for multi-family residential buildings that are 4 stories or more. Now the dwelling units themselves are covered by Standard 62.2 regardless of building height, while common areas are covered by Standard 62.1.
- The definition of “environmental tobacco smoke” (ETS) was revised to include emissions from electronic smoking devices and from smoking of cannabis.
- Operations and maintenance requirements were revised to closer align with the requirements in ASHRAE/ACCA Standard 180-2012.
- Requirements were added to the Indoor Air Quality Procedure for determining minimum ventilation rates by including consideration of the combined effects of multiple contaminants of concern on individual organ systems.
- Laboratory exhaust continues to be assigned a default of Air Class 4, but the change explicitly allows a responsible EH&S professional to determine that a lower air class is appropriate for particular systems.
- Ventilation is allowed to be reduced to zero through the use of occupancy sensors (not through contaminant or CO<sub>2</sub> measurements) for spaces of selected occupancy types, provided that ventilation is restored to  $V_{bz}$  whenever occupancy is detected.
- Changes in language related to demand control ventilation remove the assumption that the standard is intended to be used only for calculations for code review and not physical operation.

For more specific information on these changes and on other revisions made to the standard by other addenda, refer to Informative Appendix K. Users of the standard are encouraged to use the continuous maintenance procedure to suggest changes for further improvements.

A form for submitting change proposals is included in the back of the standard. The project committee for Standard 62.1 will take formal action on all change proposals received.

## 1. PURPOSE

**1.1** The purpose of this standard is to specify minimum ventilation rates and other measures intended to provide indoor air quality that is acceptable to human occupants and that minimizes adverse health effects.

**1.2** This standard is intended for regulatory application to new buildings, additions to existing buildings, and those changes to existing buildings that are identified in the body of the standard.

**1.3** This standard is intended to be used to guide the improvement of indoor air quality in existing buildings.

## 2. SCOPE

**2.1** This standard applies to spaces intended for human occupancy within buildings except those within dwelling units in residential occupancies in which occupants are nontransient.

**2.2** This standard defines requirements for ventilation and air-cleaning-system design, installation, commissioning, and operation and maintenance.

**2.3** Additional requirements for laboratory, industrial, health care, and other spaces may be dictated by workplace and other standards, as well as by the processes occurring within the space.

**2.4** Although the standard may be applied to both new and existing buildings, the provisions of this standard are not intended to be applied retroactively when the standard is used as a mandatory regulation or code.

**2.5** This standard does not prescribe specific ventilation rate requirements for spaces that contain smoking or that do not meet the requirements in the standard for separation from spaces that contain smoking.

**2.6** Ventilation requirements of this standard are based on chemical, physical, and biological contaminants that can affect air quality.

**2.7** Consideration or control of thermal comfort is not included.

**2.8** This standard contains requirements, in addition to ventilation, related to certain sources, including outdoor air, construction processes, moisture, and biological growth.

**2.9** Acceptable indoor air quality may not be achieved in all buildings meeting the requirements of this standard for one or more of the following reasons:

- a. Because of the diversity of sources and contaminants in indoor air
- b. Because of the many other factors that may affect occupant perception and acceptance of indoor air quality, such as air temperature, humidity, noise, lighting, and psychological stress
- c. Because of the range of susceptibility in the population
- d. Because outdoor air brought into the building may be unacceptable or may not be adequately cleaned

## 3. DEFINITIONS (SEE FIGURE 3.1)

**acceptable indoor air quality:** air in which there are no known contaminants at harmful concentrations as determined by cognizant authorities and with which a substantial majority (80% or more) of the people exposed do not express dissatisfaction.

**air-cleaning system:** a device or combination of devices applied to reduce the concentration of airborne contaminants such as microorganisms, dusts, fumes, respirable particles, other particulate matter, gases, vapors, or any combination thereof.

**air conditioning:** the process of treating air to meet the requirements of a conditioned space by controlling its temperature, humidity, cleanliness, and distribution.

**air, ambient:** the air surrounding a building; the source of outdoor air brought into a building.

**air, exhaust:** air removed from a space and discharged to outside the building by means of mechanical or natural ventilation systems.

**air, indoor:** the air in an enclosed occupiable space.

**air, makeup:** any combination of outdoor and transfer air intended to replace exhaust air and exfiltration.

**air, outdoor:** ambient air and ambient air that enters a building through a ventilation system, through intentional openings for natural ventilation, or by infiltration.

**air, primary:** air supplied to the ventilation zone prior to mixing with any locally recirculated air.

**air, recirculated:** air removed from a space and reused as supply air.

**air, return:** air removed from a space to be recirculated or exhausted.

**air, supply:** air delivered by mechanical or natural ventilation to a space and composed of any combination of outdoor air, recirculated air, or transfer air.

**air, transfer:** air moved from one indoor space to another.

**air, ventilation:** that portion of supply air that is outdoor air plus any recirculated air that has been treated for the purpose of maintaining acceptable indoor air quality.

**breathing zone:** the region within an occupied space between planes 3 and 72 in. (75 and 1800 mm) above the floor and more than 2 ft (600 mm) from the walls or fixed air-conditioning equipment.

**cognizant authority:** an agency or organization that has the expertise and jurisdiction to establish and regulate concentration limits for airborne contaminants, or an agency or organization that is recognized as authoritative and has the scope and expertise to establish guidelines, limit values, or concentrations levels for airborne contaminants.

**concentration:** the quantity of one constituent dispersed in a defined amount of another.

**conditioned space:** that part of a building that is heated or cooled, or both, for the comfort of occupants.

**contaminant:** an unwanted airborne constituent with the potential to reduce acceptability of the air.

**contaminant mixture:** two or more contaminants that target the same organ system.

**demand-controlled ventilation (DCV):** any means by which the breathing zone outdoor airflow ( $V_{bz}$ ) can be varied to the occupied space or spaces based on the actual or estimated number of occupants, ventilation requirements of the occupied zone, or both.

**dwelling unit:** a single unit providing complete, independent living facilities for one or more persons, including permanent provisions for living, sleeping, eating, cooking, and sanitation.

**energy recovery ventilation system:** a device or combination of devices applied to provide the outdoor air for ventilation in which energy is transferred between the intake and exhaust airstreams.

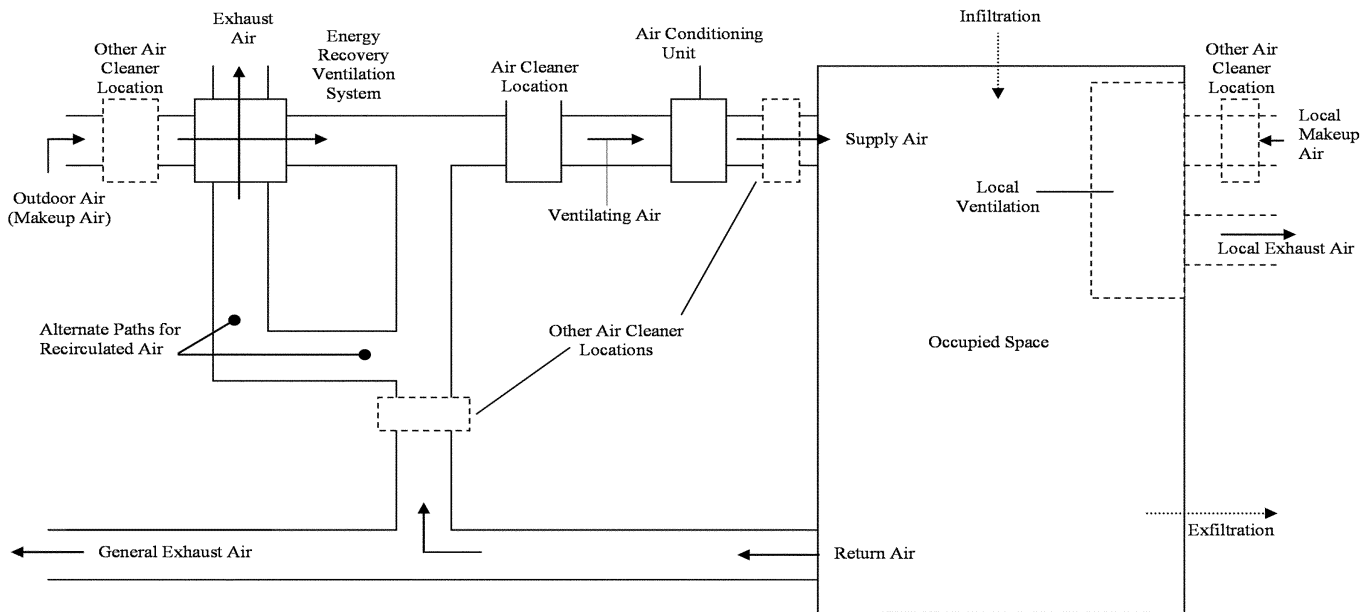

**FIGURE 3.1** Ventilation system.

**environmental tobacco smoke (ETS):** the “aged” and diluted combination of both side-stream smoke (smoke from the lit end of a cigarette or other tobacco product) and exhaled mainstream smoke (smoke that is exhaled by a smoker). ETS is commonly referred to as *secondhand smoke*. This definition includes smoke produced from the combustion of cannabis and controlled substances and the emissions produced by electronic smoking devices.

**equipment well:** an area (typically on the roof) enclosed on three or four sides by walls that are less than 75% free area, and the lesser of the length and width of the enclosure is less than three times the average height of the walls. The free area of the wall is the ratio of area of the openings through the wall, such as openings between louver blades and undercuts, divided by the gross area (length times height) of the wall.

**ETS-free area:** an area where no smoking occurs that is separated from ETS areas according to the requirements of this standard.

**Informative Note:** A no-smoking area is not necessarily an ETS-free area.

**ETS area:** spaces where smoking is permitted, as well as those not separated from spaces where smoking is permitted in accord with the requirements of Section 5 in this standard.

**exfiltration:** uncontrolled outward air leakage from conditioned spaces through unintentional openings in ceilings, floors, and walls to unconditioned spaces or the outdoors caused by pressure differences across these openings due to wind, inside-outside temperature differences (stack effect), and imbalances between outdoor and exhaust airflow rates.

**industrial space:** an indoor environment where the primary activity is production or manufacturing processes.

**infiltration:** uncontrolled inward air leakage to conditioned spaces through unintentional openings in ceilings, floors, and

walls from unconditioned spaces or the outdoors caused by the same pressure differences that induce exfiltration.

**mechanical ventilation:** ventilation provided by mechanically powered equipment such as motor-driven fans and blowers but not by devices such as wind-driven turbine ventilators and mechanically operated windows.

**microorganism:** a microscopic organism, especially a bacterium, fungus, or protozoan.

**natural ventilation:** ventilation provided by thermal, wind, or diffusion effects through doors, windows, or other intentional openings in the building.

**net occupiable area:** the floor area of an occupiable space defined by the inside surfaces of its walls but excluding shafts, column enclosures, and other permanently enclosed, inaccessible, and unoccupiable areas. Obstructions in the space, such as furnishings, display or storage racks, and other obstructions, whether temporary or permanent, are considered to be part of the net occupiable area.

**nontransient:** occupancy of a dwelling unit or sleeping unit for more than 30 days.

**occupant sensor:** a device such as a motion detector or a captive key system that detects the presence of one or more persons within a space.

**occupiable space:** an enclosed space intended for human activities, excluding those spaces that are intended primarily for other purposes, such as storage rooms and equipment rooms, and that are only occupied occasionally and for short periods of time.

**occupied mode:** when a zone is scheduled to be occupied.

**occupied-standby mode:** when a zone is scheduled to be occupied and an occupant sensor indicates zero population within the zone.

**odor:** a quality of gases, liquids, or particles that stimulates the olfactory organ.

**readily accessible:** capable of being reached quickly for operation without requiring personnel to climb over or remove obstacles or to resort to the use of unsafe climbing aids such as tables or chairs.

**residential occupancies:** occupancies that are not classified as institutional by the authority having jurisdiction and that contain permanent provisions for sleeping.

**sleeping unit:** a room or space in which people sleep that includes permanent provisions for living, eating, and either sanitation or kitchen facilities but not both. Such rooms and spaces that are also part of a dwelling unit are not sleeping units.

**unoccupied mode:** when a zone is not scheduled to be occupied.

**ventilation:** the process of supplying air to or removing air from a space for the purpose of controlling air contaminant levels, humidity, or temperature within the space.

**ventilation zone:** any indoor area that requires ventilation and comprises one or more spaces with the same occupancy category (see Table 6.2.2.1), occupant density, zone air distribution effectiveness (see Section 6.2.2.2), and design zone primary airflow (see Section 6.2.5.1) per unit area.

**Informative Note:** A ventilation zone is not necessarily an independent thermal control zone; however, spaces that can be combined for load calculation purposes can often be combined into a single zone for ventilation calculations purposes.

**volume, space:** the total volume of an occupiable space enclosed by the building envelope, plus that of any spaces permanently open to the occupiable space, such as a ceiling attic used as a ceiling return plenum.

## 4. OUTDOOR AIR QUALITY

Outdoor air quality shall be investigated in accordance with Sections 4.1 and 4.2 prior to completion of ventilation system design. The results of this investigation shall be documented in accordance with Section 4.3.

**4.1 Regional Air Quality.** The status of compliance with national ambient air quality standards shall be determined for the geographic area of the building site.

**4.1.1** In the United States, compliance status shall be either in “attainment” or “nonattainment” with the *National Ambient Air Quality Standards* (NAAQS)<sup>1</sup>. In the United States, areas with no U.S. Environmental Protection Agency (USEPA) compliance status designation shall be considered “attainment” areas.

**Informative Note:** The NAAQS are shown in Table I-1 of Informative Appendix I.

**4.2 Local Air Quality.** An observational survey of the building site and its immediate surroundings shall be conducted during hours the building is expected to be normally occupied

to identify local contaminants from surrounding facilities that will be of concern if allowed to enter the building.

**4.3 Documentation.** Documentation of the outdoor air quality investigation shall be reviewed with building owners or their representative and shall include the following as a minimum:

a. Regional air quality compliance status

**Informative Note to 4.3(a):** Regional outdoor air quality compliance status for the United States is available from USEPA located at [www.epa.gov](http://www.epa.gov).

b. Local survey information

1. Date of observations

2. Time of observations

3. Site description

4. Description of facilities on site and on adjoining properties

5. Observation of odors or irritants

6. Observation of visible plumes or visible air contaminants

7. Description of sources of vehicle exhaust on site and on adjoining properties

8. Identification of potential contaminant sources on the site and from adjoining properties, including any that operate only seasonally

c. Conclusion regarding the acceptability of outdoor air quality and the information supporting the conclusion

## 5. SYSTEMS AND EQUIPMENT

**5.1 Ventilation Air Distribution.** Ventilating systems shall be designed in accordance with the requirements of the following subsections.

**5.1.1 Designing for Air Balancing.** The ventilation air distribution system shall be provided with means to adjust the system to achieve at least the minimum ventilation airflow as required by Section 6 under any load condition.

**5.1.2 Plenum Systems.** When the ceiling or floor plenum is used both to recirculate return air and to distribute ventilation air to ceiling-mounted or floor-mounted terminal units, the system shall be engineered such that each space is provided with its required minimum ventilation airflow.

**Informative Note:** Systems with direct connection of ventilation air ducts to terminal units, for example, comply with this requirement.

**5.1.3 Documentation.** The design documents shall specify minimum requirements for air balance testing or reference applicable national standards for measuring and balancing airflow. The design documentation shall state assumptions that were made in the design with respect to ventilation rates and air distribution.

### 5.2 Exhaust Duct Location

**5.2.1** Exhaust ducts that convey Class 4 air shall be negatively pressurized relative to ducts, plenums, or occupiable spaces through which the ducts pass.

**5.2.2** Exhaust ducts under positive pressure that convey Class 2 or Class 3 air shall not extend through ducts, plenums,