

INTERNATIONAL STANDARD

NORME INTERNATIONALE

**Cable networks for television signals, sound signals and interactive services –
Part 1-2: Performance requirements for signals delivered at the system outlet in
operation**

**Réseaux de distribution par câbles pour signaux de télévision, signaux de
radiodiffusion sonore et services interactifs –
Partie 1-2: Exigences de performance relatives aux signaux délivrés à la prise
terminale en fonctionnement**



THIS PUBLICATION IS COPYRIGHT PROTECTED

Copyright © 2014 IEC, Geneva, Switzerland

All rights reserved. Unless otherwise specified, no part of this publication may be reproduced or utilized in any form or by any means, electronic or mechanical, including photocopying and microfilm, without permission in writing from either IEC or IEC's member National Committee in the country of the requester. If you have any questions about IEC copyright or have an enquiry about obtaining additional rights to this publication, please contact the address below or your local IEC member National Committee for further information.

Droits de reproduction réservés. Sauf indication contraire, aucune partie de cette publication ne peut être reproduite ni utilisée sous quelque forme que ce soit et par aucun procédé, électronique ou mécanique, y compris la photocopie et les microfilms, sans l'accord écrit de l'IEC ou du Comité national de l'IEC du pays du demandeur. Si vous avez des questions sur le copyright de l'IEC ou si vous désirez obtenir des droits supplémentaires sur cette publication, utilisez les coordonnées ci-après ou contactez le Comité national de l'IEC de votre pays de résidence.

IEC Central Office
3, rue de Varembe
CH-1211 Geneva 20
Switzerland

Tel.: +41 22 919 02 11
Fax: +41 22 919 03 00
info@iec.ch
www.iec.ch

About the IEC

The International Electrotechnical Commission (IEC) is the leading global organization that prepares and publishes International Standards for all electrical, electronic and related technologies.

About IEC publications

The technical content of IEC publications is kept under constant review by the IEC. Please make sure that you have the latest edition, a corrigenda or an amendment might have been published.

IEC Catalogue - webstore.iec.ch/catalogue

The stand-alone application for consulting the entire bibliographical information on IEC International Standards, Technical Specifications, Technical Reports and other documents. Available for PC, Mac OS, Android Tablets and iPad.

IEC publications search - www.iec.ch/searchpub

The advanced search enables to find IEC publications by a variety of criteria (reference number, text, technical committee,...). It also gives information on projects, replaced and withdrawn publications.

IEC Just Published - webstore.iec.ch/justpublished

Stay up to date on all new IEC publications. Just Published details all new publications released. Available online and also once a month by email.

Electropedia - www.electropedia.org

The world's leading online dictionary of electronic and electrical terms containing more than 30 000 terms and definitions in English and French, with equivalent terms in 14 additional languages. Also known as the International Electrotechnical Vocabulary (IEV) online.

IEC Glossary - std.iec.ch/glossary

More than 55 000 electrotechnical terminology entries in English and French extracted from the Terms and Definitions clause of IEC publications issued since 2002. Some entries have been collected from earlier publications of IEC TC 37, 77, 86 and CISPR.

IEC Customer Service Centre - webstore.iec.ch/csc

If you wish to give us your feedback on this publication or need further assistance, please contact the Customer Service Centre: csc@iec.ch.

A propos de l'IEC

La Commission Electrotechnique Internationale (IEC) est la première organisation mondiale qui élabore et publie des Normes internationales pour tout ce qui a trait à l'électricité, à l'électronique et aux technologies apparentées.

A propos des publications IEC

Le contenu technique des publications IEC est constamment revu. Veuillez vous assurer que vous possédez l'édition la plus récente, un corrigendum ou amendement peut avoir été publié.

Catalogue IEC - webstore.iec.ch/catalogue

Application autonome pour consulter tous les renseignements bibliographiques sur les Normes internationales, Spécifications techniques, Rapports techniques et autres documents de l'IEC. Disponible pour PC, Mac OS, tablettes Android et iPad.

Recherche de publications IEC - www.iec.ch/searchpub

La recherche avancée permet de trouver des publications IEC en utilisant différents critères (numéro de référence, texte, comité d'études,...). Elle donne aussi des informations sur les projets et les publications remplacées ou retirées.

IEC Just Published - webstore.iec.ch/justpublished

Restez informé sur les nouvelles publications IEC. Just Published détaille les nouvelles publications parues. Disponible en ligne et aussi une fois par mois par email.

Electropedia - www.electropedia.org

Le premier dictionnaire en ligne de termes électroniques et électriques. Il contient plus de 30 000 termes et définitions en anglais et en français, ainsi que les termes équivalents dans 14 langues additionnelles. Egalement appelé Vocabulaire Electrotechnique International (IEV) en ligne.

Glossaire IEC - std.iec.ch/glossary

Plus de 55 000 entrées terminologiques électrotechniques, en anglais et en français, extraites des articles Termes et Définitions des publications IEC parues depuis 2002. Plus certaines entrées antérieures extraites des publications des CE 37, 77, 86 et CISPR de l'IEC.

Service Clients - webstore.iec.ch/csc

Si vous désirez nous donner des commentaires sur cette publication ou si vous avez des questions contactez-nous: csc@iec.ch.

INTERNATIONAL STANDARD

NORME INTERNATIONALE

**Cable networks for television signals, sound signals and interactive services –
Part 1-2: Performance requirements for signals delivered at the system outlet in
operation**

**Réseaux de distribution par câbles pour signaux de télévision, signaux de
radiodiffusion sonore et services interactifs –
Partie 1-2: Exigences de performance relatives aux signaux délivrés à la prise
terminale en fonctionnement**

INTERNATIONAL
ELECTROTECHNICAL
COMMISSION

COMMISSION
ELECTROTECHNIQUE
INTERNATIONALE

PRICE CODE
CODE PRIX

W

ICS 33.120.10; 33.160; 35.110

ISBN 978-2-8322-1436-7

**Warning! Make sure that you obtained this publication from an authorized distributor.
Attention! Veuillez vous assurer que vous avez obtenu cette publication via un distributeur agréé.**

CONTENTS

FOREWORD.....	4
INTRODUCTION.....	6
1 Scope.....	9
2 Normative references	9
3 Terms, definitions, symbols and abbreviations.....	10
3.1 Terms and definitions.....	10
3.2 Abbreviations.....	17
4 Methods of measurement	18
5 Subjective quality of television pictures in relation to the main impairments of the analogue composite television signal.....	19
5.1 Subjective quality scale.....	19
5.2 Subjective quality and objective parameters.....	20
6 Summation of the impairments	23
6.1 Impairments to be summed	23
6.2 Summation laws.....	23
6.2.1 General	23
6.2.2 Voltage addition.....	23
6.2.3 Power addition.....	24
6.3 Examples.....	24
7 Performance requirements in operation	24
7.1 General.....	24
7.2 Impedance	25
7.3 Performance requirements at the terminal input	25
7.3.1 Definition	25
7.3.2 Signal level.....	25
7.3.3 Other parameters	25
7.4 Performance requirements at system outlets.....	25
7.4.1 Minimum and maximum carrier levels	25
7.4.2 Mutual isolation between system outlets	26
7.4.3 Isolation between individual outlets in one household	26
7.4.4 Isolation between forward and return path	26
7.4.5 Long-term frequency stability of distributed carrier signals at any system outlet.....	26
7.4.6 Carrier level differences at system outlet	26
7.4.7 Frequency response within a television channel	26
7.4.8 Random noise at system outlet.....	26
7.4.9 Interference to television channels.....	29
Annex A (normative) RF carrier to noise ratio	31
A.1 AM-VSB modulated signals.....	31
A.1.1 General	31
A.1.2 Definition	31
A.1.3 TV receiver IF filtering process	31
A.1.4 Equivalent noise bandwidth	31
A.1.5 AM demodulation process.....	32
A.2 FM modulated signals	33

Annex B (informative) Examples of summation of impairments.....	34
B.1 Voltage addition.....	34
B.2 Power addition.....	34
Bibliography.....	36
Figure 1 – CATV/MATV/SMATV cable network – Performance requirements	7
Figure 2 – Examples of location of HNI for various home network types.....	14
Figure 3 – Signal to echo ratio (dB) versus echo delay (μs)	22
Figure A.1 – Example of a TV receiver IF filter (systems B and G)	31
Figure A.2 – Example of a demodulated TV signal (systems B and G)	32
Table 1 – Methods of measurement of IEC 60728-1 applicable in operation.....	19
Table 2 – Impairment units versus subjective quality.....	20
Table 3 – Impairment grade versus un-weighted white noise	21
Table 4 – Impairment grade versus differential gain	21
Table 5 – Impairment grade versus differential phase	21
Table 6 – Impairment grade versus short time linear distortion ($2T$ pulse).....	21
Table 7 – Impairment grade versus chrominance-luminance gain inequality.....	21
Table 8 – Impairment grade versus chrominance-luminance delay inequality	22
Table 9 – Impairment grade versus echo rating ($1 \mu\text{s}$ echo delay).....	22
Table 10 – Correction factors to be applied for delays different from $1 \mu\text{s}$	22
Table 11 – Carrier-to-noise ratios at system outlet (analogue television) in operation	27
Table 12 – RF signal-to-noise ratios at system outlet (digital television) in operation	27
Table 13 – Carrier-to-noise ratios at system outlet (sound radio) in operation	29
Table B.1 – Examples of voltage addition	34
Table B.2 – Examples of power addition	35

INTERNATIONAL ELECTROTECHNICAL COMMISSION

CABLE NETWORKS FOR TELEVISION SIGNALS, SOUND SIGNALS AND INTERACTIVE SERVICES –

Part 1-2: Performance requirements for signals delivered at the system outlet in operation

FOREWORD

- 1) The International Electrotechnical Commission (IEC) is a worldwide organization for standardization comprising all national electrotechnical committees (IEC National Committees). The object of IEC is to promote international co-operation on all questions concerning standardization in the electrical and electronic fields. To this end and in addition to other activities, IEC publishes International Standards, Technical Specifications, Technical Reports, Publicly Available Specifications (PAS) and Guides (hereafter referred to as "IEC Publication(s)"). Their preparation is entrusted to technical committees; any IEC National Committee interested in the subject dealt with may participate in this preparatory work. International, governmental and non-governmental organizations liaising with the IEC also participate in this preparation. IEC collaborates closely with the International Organization for Standardization (ISO) in accordance with conditions determined by agreement between the two organizations.
- 2) The formal decisions or agreements of IEC on technical matters express, as nearly as possible, an international consensus of opinion on the relevant subjects since each technical committee has representation from all interested IEC National Committees.
- 3) IEC Publications have the form of recommendations for international use and are accepted by IEC National Committees in that sense. While all reasonable efforts are made to ensure that the technical content of IEC Publications is accurate, IEC cannot be held responsible for the way in which they are used or for any misinterpretation by any end user.
- 4) In order to promote international uniformity, IEC National Committees undertake to apply IEC Publications transparently to the maximum extent possible in their national and regional publications. Any divergence between any IEC Publication and the corresponding national or regional publication shall be clearly indicated in the latter.
- 5) IEC itself does not provide any attestation of conformity. Independent certification bodies provide conformity assessment services and, in some areas, access to IEC marks of conformity. IEC is not responsible for any services carried out by independent certification bodies.
- 6) All users should ensure that they have the latest edition of this publication.
- 7) No liability shall attach to IEC or its directors, employees, servants or agents including individual experts and members of its technical committees and IEC National Committees for any personal injury, property damage or other damage of any nature whatsoever, whether direct or indirect, or for costs (including legal fees) and expenses arising out of the publication, use of, or reliance upon, this IEC Publication or any other IEC Publications.
- 8) Attention is drawn to the Normative references cited in this publication. Use of the referenced publications is indispensable for the correct application of this publication.
- 9) Attention is drawn to the possibility that some of the elements of this IEC Publication may be the subject of patent rights. IEC shall not be held responsible for identifying any or all such patent rights.

International Standard IEC 60728-1-2 has been prepared by technical area 5: Cable networks for television signals, sound signals and interactive services, of IEC technical committee 100: Audio, video and multimedia systems and equipment.

This second edition cancels and replaces the first edition published in 2009, and constitutes a technical revision.

This edition includes the following significant technical changes with respect to the previous edition:

- update of performance requirements in Clause 7 to include those for DVB-T2 signals.

This International Standard is to be used in conjunction with IEC 60728-1:2014.

The text of this standard is based on the following documents:

FDIS	Report on voting
100/2246/FDIS	100/2282/RVD

Full information on the voting for the approval of this standard can be found in the report on voting indicated in the above table.

This publication has been drafted in accordance with the ISO/IEC Directives, Part 2.

A list of all parts of the IEC 60728 series, published under the general title *Cable networks for television signals, sound signals and interactive services*, can be found on the IEC website.

The committee has decided that the contents of this publication will remain unchanged until the stability date indicated on the IEC web site under "<http://webstore.iec.ch>" in the data related to the specific publication. At this date, the publication will be

- reconfirmed,
- withdrawn,
- replaced by a revised edition, or
- amended.

INTRODUCTION

Standards and deliverables of the IEC 60728 series deal with cable networks including equipment and associated methods of measurement for headend reception, processing and distribution of television and sound signals, and for processing, interfacing and transmitting all kinds of data signals for interactive services using all applicable transmission media. These signals are typically transmitted in networks by frequency-multiplexing techniques.

This includes for instance

- regional and local broadband cable networks,
- extended satellite and terrestrial television distribution systems,
- individual satellite and terrestrial television receiving systems,

and all kinds of equipment, systems and installations used in such cable networks, distribution and receiving systems.

The extent of this standardization work is from the antennas and/or special signal source inputs to the headend or other interface points to the network up to the terminal input of the customer premises equipment.

The standardization work will consider coexistence with users of the RF spectrum in wired and wireless transmission systems.

The standardization of any user terminals (i.e. tuners, receivers, decoders, multimedia terminals, etc.) as well as of any coaxial, balanced and optical cables and accessories thereof is excluded.

The reception of television signals inside a building requires an outdoor antenna and a distribution network to convey the signal to the TV receivers. In a building divided into apartment blocks, the signals received by the antennas are distributed by the MATV/SMATV cable network up to the home network interface (HNI). The television signals are then distributed (inside the home) by home networks (HN) of various types up to the system outlet or terminal input. The cable network can support two way operation, from the system outlet (or terminal input) towards the headend.

The home network can use coaxial cables, balanced pair cables, fibre optic cables (glass or plastic) and also wireless links inside a room (or a small number of adjacent rooms) to replace wired cords.

IEC 60728-1-2 (this standard) deals with the requirements to be fulfilled at the system outlet or terminal input, when the CATV/MATV/SMATV system is in operation.

These performance requirements for signals at the system outlet or terminal input in operation are derived from considerations of the characteristics of the received signals at the input of the headend (see Clause 6 of IEC 60728-1:2014) and the summation of the impairments produced by the headend, the CATV/MATV/SMATV network and the home network, when the requirements given in IEC 60728-1:2014 and IEC 60728-1-1 are fulfilled.

This standard gives the guidelines for calculation of the operational characteristics at system outlet, taking into account the performance requirements of the CATV/MATV/SMATV network, of the home networks and of the received signals, given in the International Standards IEC 60728-1:2014 and 60728-1-1.

Figure 1 shows the main sections of a general CATV/MATV/SMATV system, indicating the parts of the IEC 60728-1 series where the relevant performance requirements are indicated.

- The requirements for the signals received at the headend are given in Clause 6 of IEC 60728-1:2014.
- The requirements for the CATV/MATV/SMATV cable network, assuming an unimpaired input signal at the input of the headend, up to the system outlet are given in IEC 60728-1:2014, Clause 5.
- The requirements for the CATV/MATV/SMATV cable network up to the home network interface (HNI) are given in IEC 60728-1:2014, Clause 7, assuming an unimpaired input signal at the input of the headend.
- The specific requirements from HNI to the system outlet or terminal input are given in IEC 60728-1-1:2014, Clause 5, assuming an unimpaired input signal at the HNI.
- The requirements at the system outlet in operation are given in Clause 7 of this standard.

The expression in operation means that the received signals, with their impairments, are applied to the headend input of the CATV/MATV/SMATV cable network. The requirements at the system outlet in operation are derived, therefore, by summing the impairments of the various cascaded parts of the system and of the input signal.

When a change of signal format from analogue to analogue (e.g. from FM to AM-VSB) or from digital to digital (e.g. from QPSK to QAM) or from digital to analogue (e.g. from DVB-S/S2 to AM-VSB or DVB-T to AM-VSB) is made at the headend, the summation of the impairments that produce a relaxation of requirements at system outlet does not apply. Such a case will be the equivalence of unimpaired signals applied at the headend input. Therefore, the requirements at system outlet given in IEC 60728-1:2014 apply.

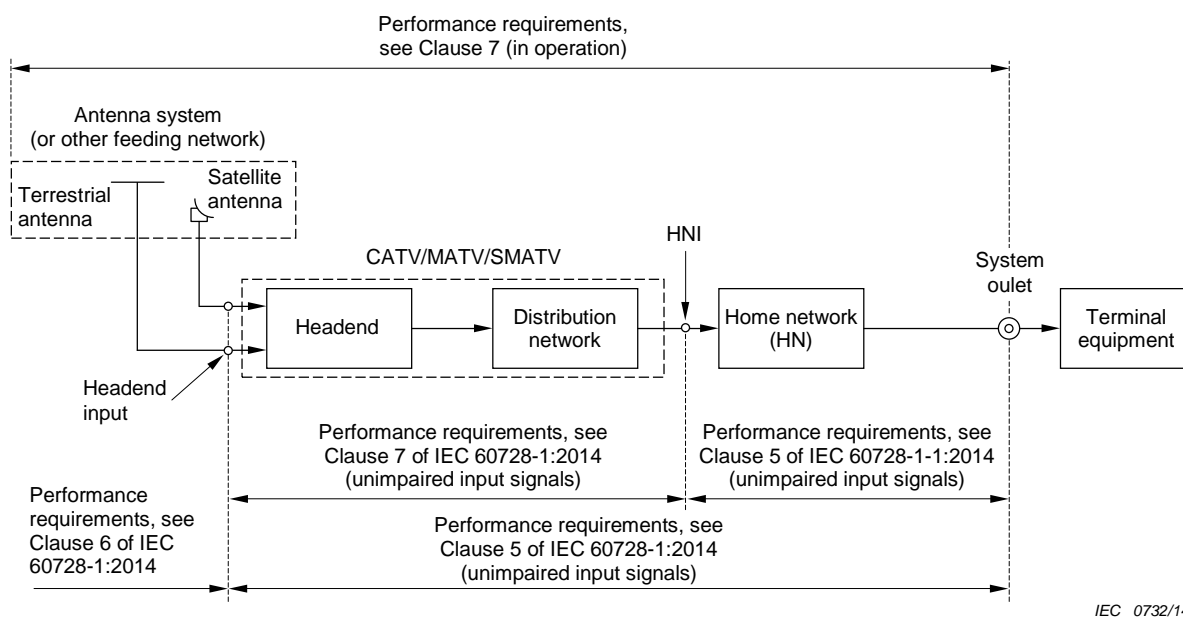

Diagram of the main sections of a CATV/MATV/SMATV cable network and the relevant parts of the IEC 60728-1 series where the requirements are indicated.

Figure 1 – CATV/MATV/SMATV cable network – Performance requirements

This standard also provides references for the basic methods of measurement of the operational characteristics of the downstream cable network in order to assess its performance.

All requirements refer to the performance limits to be achieved in operation at any system outlet when terminated in a resistance equal to the nominal load impedance of the system,

unless otherwise specified. Where system outlets are not used, the above applies to the terminal input.

If the home network is subdivided into a number of parts, using different transmission media (e.g. coaxial cabling, balanced cabling, optical cabling, wireless links) the accumulation of degradations should not exceed the figures given below.

NOTE Performance requirements of return paths as well as special methods of measurement for the use of the return paths in cable networks are described in IEC 60728-10.

CABLE NETWORKS FOR TELEVISION SIGNALS, SOUND SIGNALS AND INTERACTIVE SERVICES –

Part 1-2: Performance requirements for signals delivered at the system outlet in operation

1 Scope

This part of IEC 60728 provides the minimum performance requirements to be fulfilled in operation at the system outlet or terminal input and describes the summation criteria for the impairments present in the received signals and those produced by the CATV/MATV/SMATV cable network, including individual receiving systems.

In a building divided into apartment blocks, the signals received by the antennas are distributed by the MATV/SMATV cable network up to the home network interface (HNI). The television signals are then distributed (inside the home) by home networks (HN) of various types up to the system outlet or terminal input. The cable network can support two way operation, from the system outlet (or terminal input) towards the headend.

The home network can use coaxial cables, balanced pair cables, fibre optic cables (glass or plastic) and also wireless links inside a room (or a small number of adjacent rooms) to replace wired cords.

This part of IEC 60728 is applicable to cable networks intended for television signals, sound signals and interactive services operating between about 5 MHz and 3 000 MHz. The frequency range is extended to 6 000 MHz for home distribution techniques that replace wired cords with a wireless two way communication inside a room (or a small number of adjacent rooms) that uses the 5 GHz to 6 GHz frequency band.

2 Normative references

The following documents, in whole or in part, are normatively referenced in this document and are indispensable for its application. For dated references, only the edition cited applies. For undated references, the latest edition of the referenced document (including any amendments) applies.

IEC 60050-705, *International Electrotechnical Vocabulary – Chapter 705: Radio wave propagation*

IEC 60050-712, *International Electrotechnical Vocabulary – Chapter 712: Antennas*

IEC 60050-725, *International Electrotechnical Vocabulary – Chapter 725: Space radiocommunications*

IEC 60728-1:2014, *Cable networks for television signals, sound signals and interactive services – Part 1: System performance of forward paths*

IEC 60728-1-1:2014, *Cable networks for television signals, sound signals and interactive services – Part 1-1: RF cabling for two way home networks*

IEC 60728-3:2010, *Cable networks for television signals sound signals and interactive services – Part 3: Active wideband equipment for cable networks*