

ETSI TS 129 415 V14.0.0 (2017-04)



Universal Mobile Telecommunications System (UMTS); Core network Nb interface user plane protocols (3GPP TS 29.415 version 14.0.0 Release 14)



Reference

RTS/TSGC-0329415ve00

Keywords

UMTS

ETSI

650 Route des Lucioles
F-06921 Sophia Antipolis Cedex - FRANCE

Tel.: +33 4 92 94 42 00 Fax: +33 4 93 65 47 16

Siret N° 348 623 562 00017 - NAF 742 C
Association à but non lucratif enregistrée à la
Sous-Préfecture de Grasse (06) N° 7803/88

Important notice

The present document can be downloaded from:

<http://www.etsi.org/standards-search>

The present document may be made available in electronic versions and/or in print. The content of any electronic and/or print versions of the present document shall not be modified without the prior written authorization of ETSI. In case of any existing or perceived difference in contents between such versions and/or in print, the only prevailing document is the print of the Portable Document Format (PDF) version kept on a specific network drive within ETSI Secretariat.

Users of the present document should be aware that the document may be subject to revision or change of status.

Information on the current status of this and other ETSI documents is available at

<https://portal.etsi.org/TB/ETSIDeliverableStatus.aspx>

If you find errors in the present document, please send your comment to one of the following services:

<https://portal.etsi.org/People/CommiteeSupportStaff.aspx>

Copyright Notification

No part may be reproduced or utilized in any form or by any means, electronic or mechanical, including photocopying and microfilm except as authorized by written permission of ETSI.

The content of the PDF version shall not be modified without the written authorization of ETSI.

The copyright and the foregoing restriction extend to reproduction in all media.

© European Telecommunications Standards Institute 2017.

All rights reserved.

DECT™, **PLUGTESTS™**, **UMTS™** and the ETSI logo are Trade Marks of ETSI registered for the benefit of its Members.

3GPP™ and **LTE™** are Trade Marks of ETSI registered for the benefit of its Members and of the 3GPP Organizational Partners.

oneM2M logo is protected for the benefit of its Members

GSM® and the GSM logo are Trade Marks registered and owned by the GSM Association.

Intellectual Property Rights

IPRs essential or potentially essential to the present document may have been declared to ETSI. The information pertaining to these essential IPRs, if any, is publicly available for **ETSI members and non-members**, and can be found in ETSI SR 000 314: "*Intellectual Property Rights (IPRs); Essential, or potentially Essential, IPRs notified to ETSI in respect of ETSI standards*", which is available from the ETSI Secretariat. Latest updates are available on the ETSI Web server (<https://ipr.etsi.org>).

Pursuant to the ETSI IPR Policy, no investigation, including IPR searches, has been carried out by ETSI. No guarantee can be given as to the existence of other IPRs not referenced in ETSI SR 000 314 (or the updates on the ETSI Web server) which are, or may be, or may become, essential to the present document.

Foreword

This Technical Specification (TS) has been produced by ETSI 3rd Generation Partnership Project (3GPP).

The present document may refer to technical specifications or reports using their 3GPP identities, UMTS identities or GSM identities. These should be interpreted as being references to the corresponding ETSI deliverables.

The cross reference between GSM, UMTS, 3GPP and ETSI identities can be found under <http://webapp.etsi.org/key/queryform.asp>.

Modal verbs terminology

In the present document "**shall**", "**shall not**", "**should**", "**should not**", "**may**", "**need not**", "**will**", "**will not**", "**can**" and "**cannot**" are to be interpreted as described in clause 3.2 of the [ETSI Drafting Rules](#) (Verbal forms for the expression of provisions).

"**must**" and "**must not**" are **NOT** allowed in ETSI deliverables except when used in direct citation.

Contents

Intellectual Property Rights	2
Foreword.....	2
Modal verbs terminology.....	2
Foreword.....	5
Introduction	5
1 Scope	6
2 References	6
3 Definitions, symbols and abbreviations	7
3.1 Definitions	7
3.2 Symbols.....	7
3.3 Abbreviations	7
4 User Plane	7
4.1 General aspects.....	7
4.2 Operational and Functional Aspects.....	8
5 Transparent Mode	8
6 Support mode for predefined SDU sizes.....	8
6.1 General	8
6.2 Nb UP protocol layer services in Support Mode.....	8
6.3 Services expected from the Transport Network Layer.....	8
6.4 Functions of the Nb UP protocol layer in Support Mode.....	9
6.4.1 Functional model of the Nb UP protocol layer in Support Mode.....	9
6.4.2 Frame handler function.....	9
6.4.3 Procedure control functions	9
6.4.4 Non Access Stratum data streams specific functions.....	9
6.4.4.1 Frame quality classification	9
6.4.4.1.1 General	9
6.4.4.1.2 Handling of FQC information	10
6.5 Elementary procedures	10
6.5.1 Transfer of User Data procedure.....	10
6.5.1.1 Successful operation.....	10
6.5.1.2 Unsuccessful operation	10
6.5.2 Initialisation procedure	10
6.5.2.1 Successful operation.....	10
6.5.2.2 Unsuccessful operation	11
6.5.3 Rate Control.....	11
6.5.3.1 Successful operation.....	11
6.5.3.1.1 Rate control for codecs other than the EVS codec	11
6.5.3.1.2 Rate and mode control for the EVS codec.....	11
6.5.3.1.3 Interworking of rate control between compatible AMR-WB and EVS codec configurations.....	12
6.5.3.2 Unsuccessful operation	12
6.5.4 Time Alignment.....	13
6.5.4.1 Successful operation.....	13
6.5.4.2 Unsuccessful operation	13
6.5.5 Handling of Error Event procedure.....	13
6.5.5.1 Successful operation.....	13
6.5.5.2 Unsuccessful operation	13
6.6 Elements for Nb UP communication in Support mode	13
6.7 Handling of unknown, unforeseen and erroneous protocol data	13
7 Communication Primitives for the Nb UP protocol layer	13
7.1 Modelling Principle	13
7.2 Primitives towards the upper layers at the CNL-SAP	13

7.3	Primitives towards the transport layers at TNL-SAP	13
7.3.1	General.....	13
7.3.2	ATM/AAL2 based Transport Layer	14
7.3.2.1	General	14
7.3.2.2	AAL2 Service Primitives used by the Nb UP protocol.....	14
7.3.3	GTP-U based Transport Layer.....	14
7.3.4	RTP/UDP/IP based Transport Layer.....	14
8	Evolution of Nb UP Protocol	14
Annex A (informative): Change history		15
History		16

Foreword

This Technical Specification has been produced by the 3rd Generation Partnership Project (3GPP).

The contents of the present document are subject to continuing work within the TSG and may change following formal TSG approval. Should the TSG modify the contents of the present document, it will be re-released by the TSG with an identifying change of release date and an increase in version number as follows:

Version x.y.z

where:

- x the first digit:
 - 1 presented to TSG for information;
 - 2 presented to TSG for approval;
 - 3 or greater indicates TSG approved document under change control.
- y the second digit is incremented for all changes of substance, i.e. technical enhancements, corrections, updates, etc.
- z the third digit is incremented when editorial only changes have been incorporated in the document.

Introduction

The present document specifies the user plane protocol used between two Media Gateways in the CS core network. Through out the present document this protocol shall be referred to as the Nb UP protocol. The Nb UP protocol is for a large part identical to the Iu UP protocol (see 3GPP TS 25.415 [2]), and only the differences between the two protocols are specified. This specification defines the applicability of the UP, as defined in 3GPP TS 25.415 [2], for the Nb interface only.

Given that the Nb UP uses the same PDU types as the Iu UP, the term IuFP is used to refer to the common framing.

For the purpose of the present document, any occurrence of the term "Iu UP" in the corresponding sections of 3GPP TS 25.415 [2], shall be interpreted as "Nb UP".

1 Scope

The present document specifies the user plane protocol of the bearer used between two MGWs within the BICC-based CS core network, called the Nb UP protocol. The present document assumes the implementation of the split between call control and the bearer transport and control, as specified in 3GPP TS 23.205 [1], see figure 1. Note that the present document does not preclude an implementation of a combined MSC Server and MGW.

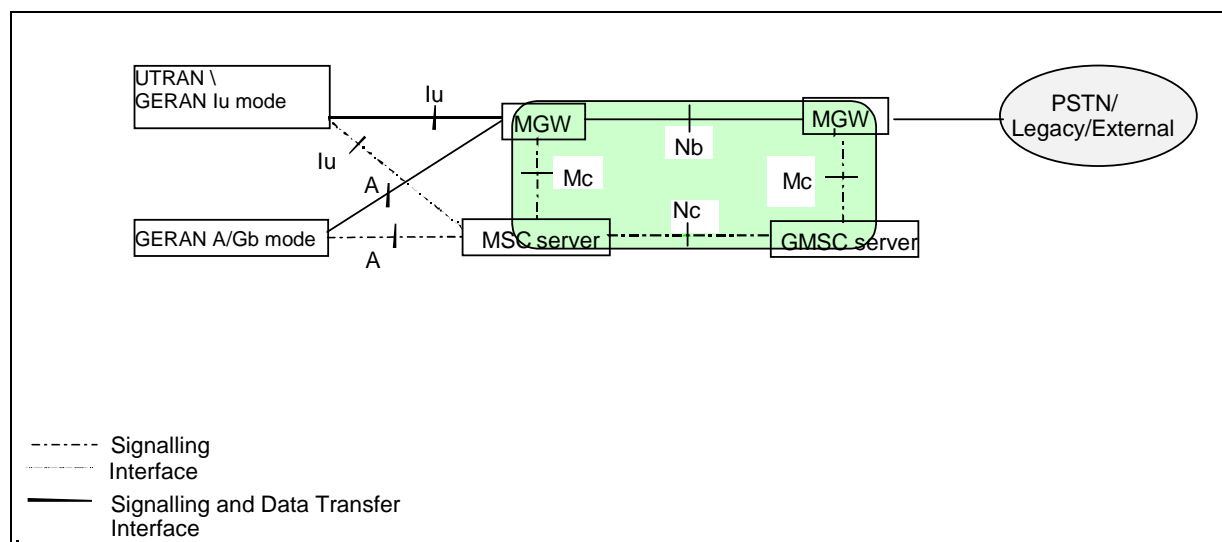

Figure 1: CS core network logical architecture

2 References

The following documents contain provisions which, through reference in this text, constitute provisions of the present document.

- References are either specific (identified by date of publication, edition number, version number, etc.) or non-specific.
- For a specific reference, subsequent revisions do not apply.
- For a non-specific reference, the latest version applies. In the case of a reference to a 3GPP document (including a GSM document), a non-specific reference implicitly refers to the latest version of that document *in the same Release as the present document*.

- [1] 3GPP TS 23.205: "Bearer Independent CS Core Network; Stage 2"
- [2] 3GPP TS 25.415: "UTRAN Iu Interface User Plane Protocols"
- [3] 3GPP TS 29.232: "Media Gateway Controller; Media Gateway interface; Stage 3"
- [4] 3GPP TS 29.414: "Core Network Nb Data Transport and Transport Signalling"
- [5] 3GPP TR 41.001: "GSM Release specifications"
- [6] 3GPP TR 21.905: "Vocabulary for 3GPP Specifications"
- [7] IETF RFC 1889: "RTP A Transport Protocol for Real Time Applications"
- [8] ITU-T I.366.1 (06/98): "Segmentation and Reassembly Service Specific Convergence Sublayer for the AAL type 2"
- [9] 3GPP TS 26.445: "Codec for Enhanced Voice Services (EVS); Detailed Algorithmic Description".
- [10] 3GPP TS 26.453: "Codec for Enhanced Voice Services (EVS); Speech codec frame structure".